



# WING ES 7-12

## WETAC ENERGY SOLUTIONS



**Designlife**

6-9 Years

### WING BATTERIES - ES 7-12

Stationary, maintenance-free, sealed lead battery 12V – 7Ah

WING ES Batteries utilize superior cast grid plates with electrolyte absorbed in a glass fiber separator (AGM). The features of the ES range make them extremely versatile and adaptable for use in the fields of security lighting, UPS systems, IT / data centers, telecommunications applications etc.

#### Electrical specifications

Nominal Voltage:	12 V
Capacity 25°C to 1.8V/C (20 h):	7,0 Ah
Capacity 25°C to 1.8V/C (10 h):	6,6 Ah
Capacity 25°C to 1.8V/C (8 h):	6,1 Ah
Capacity 25°C to 1.8V/C (3 h):	5,2 Ah
Capacity 25°C to 1.8V/C (1 h):	3,7 Ah
Self discharge @ 25°C per month:	≈ 2,5 - 3%
Internal resistance fully charged:	≈ 28 mΩ
Max. current (charging) @ 25°C:	2,16 A
Max. current (discharging) @ 25°C (5 Sec.):	108 A
Charge Voltage (Float) @ 25°C (-18mV/°C):	2,27-2,29 V/C
Charge Voltage (Cyclic) @ 25°C (-30mV/°C):	2,41-2,48 V/C

#### Other specifications

Float Design Life @ 25°C:	6-9 Years
Dimensions LxWxH (mm):	151x65x94
Total Height (mm):	100 mm
Operating Temperature:	-20 to 50°C
Separator:	AGM
Grid alloy:	Calcium / Tin lead alloy
Case and lid material:	ABS
Electrolyte:	Sulphuric Acid
Terminal / Lenght:	.187 (F1) FastOn
Optional terminal types:	none
Torque setting:	N/A
Weight:	2,20 kg (±5%)

#### Design features

- Life time 6-9 Years
- High rate discharge optimised
- Advanced Lead-calcium cast grid design
- Enhanced AGM separators for improved electrolyte distribution
- Capacity range: 1,2 Ah to 65 Ah
- ES 12V Batteries with VdS standard: 1,2 | 2,3 | 3,2 | 7 | 12 | 18 | 26 | 40 | 65 Ah
- Designed to comply with standards: DIN EN 60896-2, DIN 43534, BS 6290, IEC 60896-21/22, IEC 61056
- Extremely low gassing
- Low self discharge
- FAA and IATA approved non-hazardous

#### Dimensions

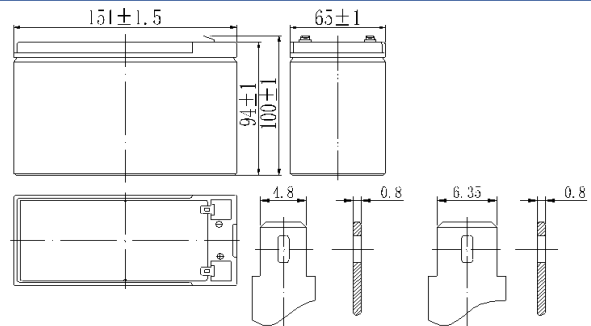

#### Performance – Current(A) @ 25°C

V/C	5m	10m	15m	20m	25m	30m	35m	40m	45m	50m	55m	60m	90m	2h	3h	4h	5h	6h	7h	8h	9h	10h	12h	20h
1,80	23,0	13,7	11,0	8,78	6,98	6,42	5,70	5,15	4,59	4,34	4,04	3,72	2,79	2,42	1,75	1,40	1,19	1,00	0,87	0,77	0,70	0,66	0,56	0,35
1,75	24,6	14,5	11,7	9,29	7,42	6,66	5,92	5,34	4,77	4,51	4,13	3,83	2,88	2,48	1,80	1,44	1,22	1,02	0,89	0,79	0,72	0,67	0,58	0,36
1,70	25,7	15,1	12,1	9,60	7,70	6,84	6,20	5,49	4,91	4,60	4,25	3,92	2,94	2,52	1,81	1,45	1,23	1,03	0,89	0,80	0,73	0,67	0,58	0,36
1,65	26,9	15,8	12,5	9,90	8,06	7,06	6,34	5,72	5,05	4,69	4,38	4,03	3,05	2,54	1,83	1,46	1,24	1,04	0,90	0,81	0,73	0,68	0,58	0,36
1,60	27,5	16,3	12,9	10,2	8,21	7,20	6,39	5,77	5,15	4,75	4,41	4,07	3,06	2,56	1,84	1,47	1,25	1,04	0,91	0,81	0,73	0,68	0,58	0,37

#### Performance – Watt per Cell (W/C) @ 25°C

V/C	5m	10m	15m	20m	25m	30m	35m	40m	45m	50m	55m	60m	90m	2h	3h	4h	5h	6h	7h	8h	9h	10h	12h	20h
1,80	40,2	24,2	19,7	15,7	12,4	11,5	10,2	9,32	8,33	7,92	7,40	6,87	5,17	4,52	3,32	2,68	2,30	1,95	1,70	1,51	1,38	1,30	1,13	0,71
1,75	43,0	25,5	20,8	16,7	13,2	11,9	10,6	9,63	8,63	8,20	7,57	7,05	5,33	4,62	3,40	2,75	2,37	1,98	1,73	1,55	1,42	1,31	1,15	0,71
1,70	44,7	26,5	21,5	17,3	13,8	12,2	11,1	9,88	8,85	8,33	7,73	7,18	5,42	4,67	3,43	2,77	2,37	2,00	1,73	1,56	1,43	1,28	1,15	0,72
1,65	46,7	27,7	22,2	17,8	14,2	12,6	11,3	10,2	9,07	8,48	7,95	7,37	5,62	4,70	3,45	2,78	2,38	2,00	1,73	1,57	1,44	1,33	1,15	0,72
1,60	47,5	28,3	22,8	18,2	14,6	12,8	11,3	10,3	9,23	8,57	8,00	7,42	5,62	4,72	3,45	2,78	2,38	2,00	1,77	1,57	1,44	1,33	1,16	0,73



<http://www.wetac.com>

**Wetac Stand-By Nederland B.V.**  
Galvanistraat 117  
6716 AE Ede  
The Netherlands  
+31 318 696 190  
orderdesk@wetac.nl

**Wetac Stand-By Nederland B.V. OS.**  
Nadrázní 344/23  
150 00 Praha 5  
Czech Republic  
+420 732 172800  
Mail: standby@wetac.com

**Wetac Hellas S.A.**  
7 Neratzoulas Street  
13672 Acharnes - Attica  
Greece  
+30 210 2446 848  
info@wetac.gr

**Wetac UK Ltd.**  
Westgate House  
44 Hale Road  
WA 14 2EX Altrincham - Chesire  
United Kingdom  
+44 7788 711638  
info@wetac.co.uk

**BSOL Batteriesysteme GmbH**  
Bonner Strasse 365  
40589 Düsseldorf (Benrath)  
Germany  
+49 211 387899-40  
info@bsol.de

**Wetac Swiss GmbH**  
Weilstrasse 79  
4125 Riehen - Basel  
Switzerland  
+41 61 643 7066  
info@wetac.ch



<https://www.facebook.com/wetacbatteries>

<http://linkedin.com/company/wetac-battery-company>

