

**XTRA CAPACITY
XTRA LIFETIME
XTRA MILEAGE**

APPLICATIONS

Powerchairs / home mobility equipment
Scooters, 3- and 4 wheels
Toys for children
Lifts (stairs / bathrooms)
Personal Carriers
Utility Vehicles

SPECIFICATIONS

Nominal Voltage	12V	
Nominal capacity @20 hour rate	55Ah	
Capacity at 25°C	10 hour rate	48Ah
	5 hour rate	45Ah
	1 hour rate	30Ah
Shelf time @20°C up to 70%	in months	9
Internal resistance (at 1 KHz)	approx. 7,4 mΩ	
Operating temperature for (dis)charge	-15°C to + 40°C	

DIMENSIONS

Dimensions LxWxH (T) in mm	198x166x178 (178)
Weight	15,4kg (±2%)
Separator	AGM, Advanced Glass Matt
Case and cover	ABS (UL94-V0 optional)
Terminal	M6 Bolt
Torque setting (recommended)	M6 (copper): 4 Nm
Maximum allowable torque value	M6 (copper): 6 Nm

CHARGING

Charging Voltage cycle use 14,4 to 15 Volt
Float charge Voltage 13,5 to 13,8 Volt
Charging current, minimum 5A - maximum 12A

CYCLE LIFE

To maximize the cycle life of the battery, we recommend to charge the battery fully after use. The total life of the battery, is very dependant on the correct charge and depth of discharge per cycle.

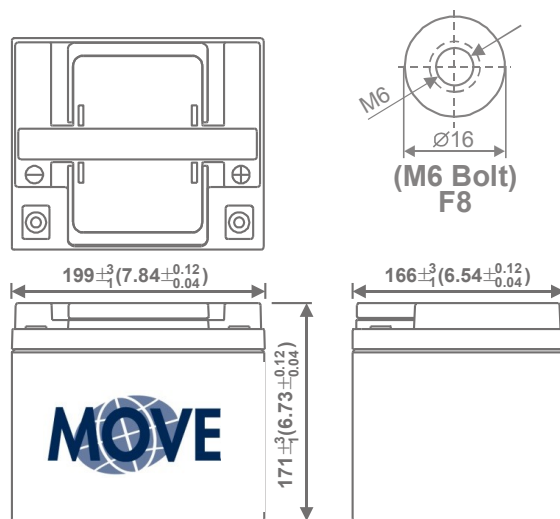

BATTERY LIFE UNDER CYCLIC USE

Tested in conformance to the BCI testing method

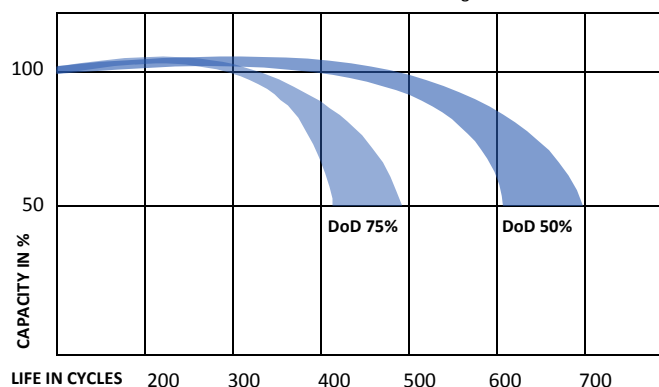

* Cycle life is measured with a discharge current 0,2C, charged 16h and rest capacity of 2/3 Cn